

Design and Construction Manual for the

kk7uq Interface Model II

Isolating Sound Card Interface for SSB Transceivers

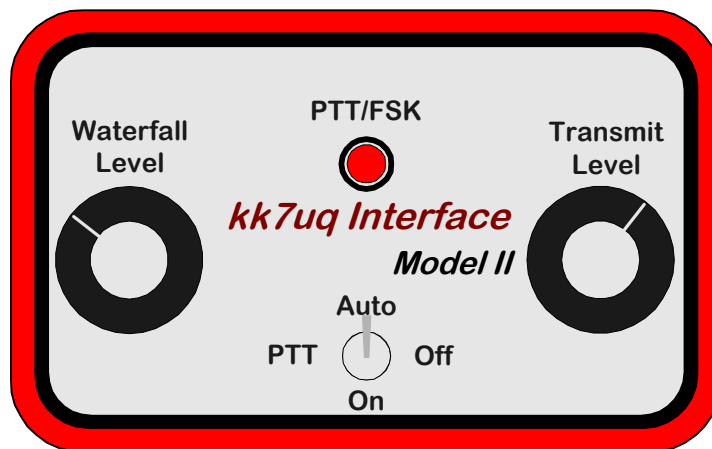

by Clint Hurd - kk7uq
Discovery Bay Computing
Port Townsend, Washington
Rev. B3 - October 21, 2003

Table of Contents

1 Introduction	1	5.2.2 SSB Rig Control Cables	15
1.1 Intended Use	1	5.3 Enclosures	18
1.2 Scope	1	5.3.1 Altoids ® Box	18
1.3 Features	1	5.3.1.1 Top of the Box	18
2 What You Will Need to Build the Interface	2	5.3.1.2 Bottom of the Box	19
2.1 Skills	2	5.3.2 KK7UQ Model II - Eagle Plastics Box	22
2.2 Tools & Materials	2	5.3.2.1 Cover Plate	22
3 Theory of Operation	3	5.3.2.1.1 Drill Template	22
3.1 PSK31 Requirements	3	5.3.2.1.2 Panel Overlay	22
3.1.1 Bandwidth	3	5.3.2.1.3 Overlay Alignment Jig	23
3.1.2 Software Functions	3	5.3.2.2 Enclosure	24
3.1.3 SSB Rig Audio Levels	3	5.3.2.2.1 Drill Template	24
3.1.4 PC Sound Card Audio Levels	3	5.3.2.2.2 Assembly of the Parts	24
3.1.5 Noise & Feedback	4	5.3.2.2.3 Legend Overlay	25
3.2 Description of Interface	5	6 Software Sources	26
3.2.1 Receive Audio Path	5	7 System Setup and Test	28
3.2.2 Transmit Audio Path	6	7.1 Load the Sound Card Program	28
3.2.3 Audio Monitor	6	7.2 Hook Up Your Rig	28
3.2.4 PTT	7	7.3 Receive Settings	29
3.2.4.1 Control and Indicator	7	7.4 Transmit Settings	30
3.2.4.2 PTT Mode Control Switch	7	7.4.1 PC Tx Level Adjust	30
3.2.4.3 FSK Control and Indicator	7	7.4.1.1 Mute Unused Sources	30
3.3 A Note of Caution About Driving the Rig with Opto-Isolators	7	7.4.1.2 Set the Initial PC Audio Level	31
4 Ordering Parts	8	7.4.2 Getting Ready to Transmit	31
4.1 Sources	8	7.4.2.1 Reduce the Rig Power Level	31
4.2 Alternate Sources	8	7.4.2.2 Set the Tx Frequency	31
4.3 Parts List	8	7.4.2.3 Tx Audio Offset	31
4.3.1 Design and PCB Package	9	7.4.2.4 Set the Initial Tx Level Controls	31
4.3.2 Circuit Board Assembly	9	7.4.2.5 Test the PTT	31
4.3.3 Plastic Box Enclosure	9	7.4.2.6 Power Settings	32
4.3.4 Serial Cable	9	7.4.2.7 Adjust the Mic and Wave Level	32
4.3.5 Audio Cables	10	7.4.2.8 Install the Audio Transducer	33
4.3.6 Rig Control Cables	10	7.4.3 Your First QSO	33
4.3.7 Rig Microphone or Accessory Connector	10	7.4.3.1 Tune Up Away from Other Stations	33
5 Assembly	11	7.4.3.2 Look for a CQ	33
5.1 PCB Assembly	11	7.4.3.3 Getting an IMD Report	34
5.1.1 Polarized Components	11	7.4.4 The IMD Report	34
5.1.2 Components Requiring Special Mounting	11	7.5 Common Problems and Their Cures	35
5.1.3 Order of Assembly	12	7.5.1 Spurs	35
5.2 Cable Assembly	15	7.5.2 Hum	35
5.2.1 Serial Port Cable	15	7.5.3 Wideband Noise	35
		7.5.4 Other Strange Audio	36
		7.5.5 Break Up of Your Audio	36
		7.6 Filtering the Audio Cable	36

1 Introduction

1.1 Intended Use - This design has been created for the amateur radio community to encourage more hams to enjoy the pleasures of the new sound card digital modes. This design is ideal for ham club construction projects and for the individual ham who likes to build his own equipment. The end result is a solid interface for use with sound card modes such as PSK31, MFSK16, RTTY, Hellschreiber, SSTV, Throb and CW.

1.2 Scope - This manual describes the design and assembly of an interface between a PC and a SSB rig. Included in this manual are sections describing the theory of operation of the interface, material list and parts ordering guidelines, assembly procedures, system setup and testing, and guidelines for where to find software for operating the many digital modes using the sound card in your PC as the signal processor.

1.3 Features - This manual describes Version II of the KK7UQ Interface. New features are shown in **RED** in the description below. The features of this design are intended to provide excellent interfacing, as well as operator friendly features not found in other interfaces. These features are:

- Ground paths between the PC and the SSB rig that travel through the interconnecting cables are completely eliminated through the use of transformers and an opto-isolator.
- Potentiometers are provided on both Rx and Tx to allow easy level adjustment during operation. Knobs are located on the top of the enclosure for easy adjustment.
- * **Two opto-isolators** are provided to allow independent activation of PTT and control signals such as FSK for RTTY mode, or keying for CW mode
- * **Two Color LED** provided to show when the PTT control line is activated or when the FSK line is pulsed.
- Switch provided to enable/disable automatic PTT, or to force the rig PTT on for manual operation and test.
- * **Audio transducer and amplifier** is provided on the interface to monitor the audio signal sent to modulate the SSB rig. The audio transducer is mounted on the PC card.
- * Design implemented on a PCB to reduce wiring lengths and simplify assembly. **The dimensions of the PCB have been reduced to allow packaging in an Altoids® box if desired.** (Altoids is a registered trademark of Callard & Bowser-Suchard Ltd.)
- Or the interface can be packaged in a standard, off the shelf enclosure consistent with the reduced size of the modern transceiver. The enclosure measures 4.1”w x 2.7”d x 1.6” h.
- Templates provided for hole location on the enclosure and top panel.
- Panel label overlays provided for top and rear panel.
- Can be interfaced to either the rig’s microphone & line out; or to a single rig accessory port if provided by the rig.

2 What You Will Need to Build the Interface

2.1 Skills - This design can be done as a home brew project that requires basic skills in electronic and mechanical assembly. To be successful at building this project, you must be able to:

- Identify basic electronic parts
- Order parts from an electronic distributor via a website (a full kit of parts is also available.)
- Solder parts to a printed circuit board
- Operate an electric hand drill
- Drill holes in an aluminum plate and in the enclosure using supplied templates.
- Cut and trim holes using the drill and an exacto knife
- Cut and trim overlays and glue them onto the panel
- Measure some voltages and currents with a multi-meter
- Determine the wiring of the microphone input of your SSB rig and build the adapter cable to connect it to the interface

To simplify the assembly process: templates are provided for drilling the enclosure and the cover plate; a two sided, plated through hole printed circuit board with solder mask and parts identification silk screen is provided to mount all electronic parts; printed overlays are provided for the panel and enclosure; a detailed bill of materials is provided for ordering the parts; and a complete assembly manual is provided.

2.2 Tools and Materials - You will need the following tools and materials

- Needle nosed pliers
- Side cutters
- Phillips screw driver
- Small blade screw driver
- Soldering iron and good quality rosin core solder
- 1/4" electric drill, with bits of 1/16, 5/64, 1/8, 7/32, 1/4, 5/16 & 1/2 inch
- 1/2" counter sink drill bit
- Exacto knife with a new, pointed blade
- Spray on contact cement
- Electronic board cleaner
- Multi-meter
- Scissors
- Tin Snips (Altoids ® box only)

3 Theory of Operation

3.1 PSK31 Requirements - The use of a PC sound card to modulate the audio of a SSB rig has seen explosive growth in the last few years. In particular, the PSK31 (Phase Shift Keyed, 31 Baud) has changed the nature of communications over ham radio and attracted thousands of hams to use this as their main mode of operation. PSK31 is extremely efficient of operating bandwidth use; typically requiring about 60 Hz for the signal. Signal separation of 100 Hz without interference is common practice. The nature of the PSK31 modulation system is such that it is effectively a two-tone modulation system. Because of this, good linearity must be provided throughout the audio path to prevent unwanted side bands from being created by the system.

3.1.1 Bandwidth - To realize this low bandwidth and close signal separation, some care must be taken in adjustment of the audio drive of the transmitter from the PC, and particular attention must be paid to minimizing stray signal pickup from sources such as the RF field of the transmitter, AC power lines and other sources. It is the job of the interface system to provide clean signals to the transmitter in this potentially hostile environment.

The basic concept is very straight forward. During transmit, audio output from the PC sound card is provided at the microphone (or accessory connector) of the SSB rig. The SSB rig is keyed using the PTT input to the rig. Data input from the operator is provided by the keyboard to the sound card software. The sound card software converts it to the modulation format and uses the sound card to create the modulated audio output for the SSB rig.

During receive, the audio from the SSB rig is connected to the audio input of the PC sound card, and the sound card software decodes the audio signal and provides text output on the screen.

3.1.2 Software Functions - The software running on the PC provides the functions of:

- Operator Interface - Keyboard and Screen
- Scanning a portion of the audio band (200 to 4000 Hz) and presenting a view of this spectrum on a waterfall or spectrum display
- Selection of a particular signal, filtering it to separate from other signals and decoding it.
- Presenting the output to the screen.
- When ready to transmit, accepting the data via keyboard and converting the keyboard data to a modulated audio output to be sent to the SSB rig.

3.1.3 SSB Rig Audio Levels - are consistent with driving speakers or headsets. These signals have an extremely wide dynamic range: from millivolts to around 5 V p-p. The PC Sound Card accepts levels up to about 5v p-p. In general, the audio levels from the rig to the sound card are compatible. If signals approach the maximum range of the sound card input, a warning message from the software will be given for the operator to reduce the audio level. The receive audio level can be controlled by RF gain of the receiver, input gain of the sound card, or a level control potentiometer in the interface. In practice, all of these controls are used during setup and operation of the system.

3.1.4 PC Sound Card Audio Levels - The audio levels created from the sound card are in the range of 0.1 to 5 v p-p. Typical signal level is around 1V p-p. The SSB rig, however, expects signals that are compatible with microphones, i.e. in the tens of millivolts range. The interface must provide some level reduction to bring the signals to the right scale. The actual level required is a function of the microphone gain setting of the rig, the audio level of the PC sound card and a level control potentiometer in the interface. All of these controls are set during the system setup, covered in chapter 6.

3.1.5 Noise & Feedback - One problem with lower level input is that any signal picked up on the transmit audio wiring can approach the expected signal level, degrading S/N and putting unwanted signals on the transmitted audio. If the noise source is the RF created by the transmitter, feedback will occur with broad band noise resulting on the transmitted audio. There are several lines of defense that can be taken to ensure clean, quiet operation.

- Shield the cables, and provide good ground connections for all components of the system, including the PC.
- Provide a filter in the interface to remove unwanted RF signals that have been picked up. This combined with short lead lengths in the cables from the interface to the rig can be very effective.
- Eliminate any ground loop between the components that travel along the signal path which may inject common mode noise into the audio. This is done in the interface by using audio transformers on both the input and output audio paths. The PTT and FSK controls are isolated using opto-isolator components.
- Select the audio levels along the path to enhance S/N ratio when ever possible. This is covered in the chapter on system setup.
- Ensure that the audio created by the PC is in fact the ONLY audio created by the sound card software. Other inputs to the sound card exist, and can be active unless positive steps are taken to ensure that they are turned off. This is also covered in the chapter on system setup.

3.2 Description of the Interface - The schematic diagram for the PCB is shown in figure 3.1 below. Sound card or PC functions are shown on the left side of the drawing. SSB rig functions are shown on the right side of the drawing. Signal flow is indicated by arrows to show the flow from the source to the destination.

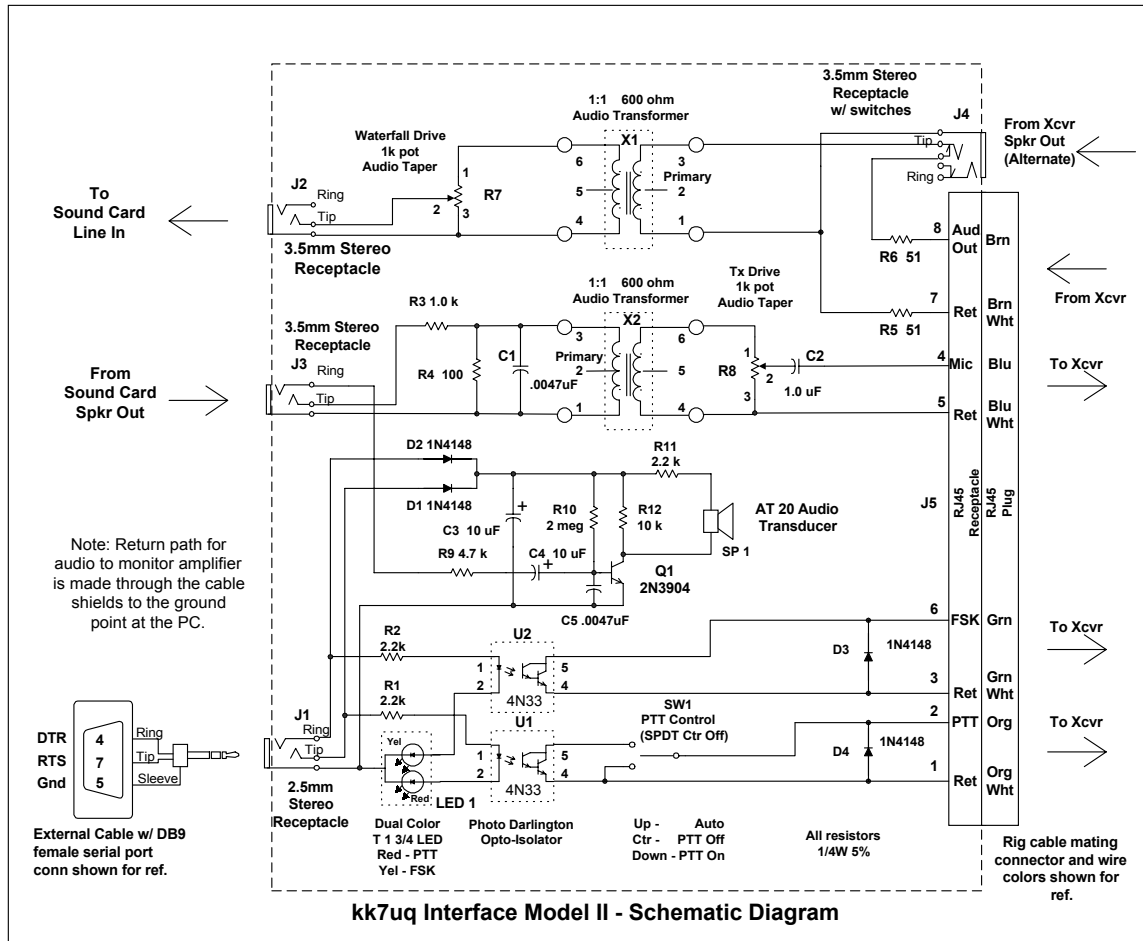

Figure 3.1 Sound Card Interface Schematic Diagram

3.2.1 Receive Audio Path - At the top of the page the flow of audio from the rig to the sound card is shown. There are two possible sources for this audio: a source terminated in an audio connector such as a 3.5mm monoaural source (speaker out, headset out or line out). The other possible source is from an accessory connector which contains both output audio, input audio, and PTT functions. The interface is designed to operate with either method of connection. If the 3.5mm audio connector in J4 is used, a switch internal to the connector is used to disconnect the audio from the RJ45 connector (J5). This prevents two sources from the rig being connected together. During the time that the plug is inserted in the jack, J4, the cable can be shorted, hence resistors R5 and R6 are used to provide a load during this short time interval.

The audio from one of these two sources is sent to the primary of transformer X1. The output of the transformer feeds potentiometer R7 which is used to control the signal output level sent on to the PC sound card. The output connector is a stereo 3.5mm jack since the sound card expects stereo input. Only the TIP (right channel) connection is used. The connection to the sound card should be a shielded stereo cable.

3.2.2 Transmit Audio Path - The next circuit down the page shows the audio path from the sound card to the rig. The sound card output is provided in the form of a shielded stereo audio cable. The TIP (right

hand channel) connection of the 3.5mm audio jack J3 carries this signal. The RING (left hand channel) is connected to the Audio Transducer monitor circuit described in 3.2.3.

The audio goes to voltage divider R3/R4. This provides a signal level reduction of about 10:1. Signal levels of around 1 volts become around 100 millivolt after this divider; additional reduction in signal is provided by potentiometer R8 on the output of transformer X2. The overall range of signal level output that can be provided to the rig can vary from about 1 millivolt to about 400 millivolt by proper adjustment of the sound card volume control, and the potentiometer on the interface.

Capacitor C1 is provided across the primary side of transformer X2. This acts as a filter for any RF present on the audio input line. The output of the X2 feeds a potentiometer (R5) to allow for final adjustment of signal level going to the SSB rig. The wiper of the potentiometer is fed through capacitor C2 to provide DC blocking of the signal sent to the SSB rig.

An RJ-45 jack is provided as the method of connecting to the SSB rig. This connector is set up to allow feeding the microphone jack of the rig, or an accessory connector, if available. Signals on this connector include the audio received from the SSB rig, the audio sent to the SSB rig, the PTT control of the rig, and a FSK control signal for RTTY use. *Notice that the return lines (normally chassis ground of the rig) are not tied together in the interface.* They are only tied together at the connector to the rig itself. This arrangement enhances low noise and cross talk on the signals to and from the rig.

3.2.3 Audio Monitor - This is a new feature of the Model II interface. It provides audio reproduction of the modulated signal being sent to the rig. The power for this monitor is provided by the voltage sent to the interface for PTT or FSK control. About 2 ma. is used by the active state of the signal to power the amplifier circuit used to drive the audio transducer.

The audio transducer is a piezo electric device built into a 1" diameter package which is mounted on the PC board assembly. It has an active frequency range of around 3000 to 5000 Hz. Since the signal being reproduces is normally in the 500 to 3000 Hz range, the amplifier is designed to create harmonics of the signal one to three octaves higher than the original signal. The resulting audio has the same characteristics as the original (warble, moving tones, cw tones etc.) but is higher in frequency. This provides a very useful monitor that can be run at low power and small enough to be resident on the PC board.

Audio level control of this signal is provided by the PC sound card volume control channel attenuator for the left channel. Muting of the monitor can also be provided by this control.

The voltage for the monitor comes from the serial control DTR or RTS lines. The voltage level of the active state of these signals is between 6 and 12 volts, depending upon the type of computer used. The diodes D1 and D2 feed capacitor C3 to filter any ripple which may be present on the control lines. Transistor Q1 is biased by resistor R10 to provide a DC operating point on the output of about 1 volt. The audio signal from J3 (ring) is fed through resistor R9 and capacitor C4 to the base of Q1. The output of Q1 varies from 0 to full scale, with some squaring of the signal. This is where the harmonics are generated to feed the audio transducer SP1. The current through the transducer is limited by R11 at about 1 ma. R12 is used to provide a DC collector current of about 1 ma.

Note that the ground return for the audio signal is done via the cable connected to J1 and gets to the audio ground at the PC. Using this return path reduces any noise which might be injected into the audio signal going to the rig.

3.2.4 PTT - The Push To Talk (PTT) rig function is used to turn on the transmitter when sending audio to the rig through the interface. The PTT Control circuit is described below.

3.2.4.1 PTT Control and Indicator - The PTT (Push to Talk) control circuit is shown at the bottom of the diagram. The interface is set up to activate PTT under the control of a RTS (request to send) line of the serial port of the PC.

The RTS line feeds Opto-Isolator U1 through a 2.2k resistor, R1. This provides enough current to activate the output of U1. The signal is returned to ground through the RED side of the dual LED indicator LED1. When RED is seen, the PTT has been activated by the PC.

Diode D4 is provided across the PTT output in case the signal is tied to an inductive load like a relay coil.

3.2.4.2 PTT Mode Control Switch - Switch SW1 provides control over the PTT lines of the rig. If the switch is in the UP position, automatic PTT has been enabled. Any time RTS on the serial port is active, the PTT output will be activated (low impedance). If the switch is in the CENTER position, the PTT lines can not be activated. If the switch is in the DOWN position, the PTT lines are forced to the active state, and the rig is keyed. This latter mode is useful for testing, and for those installations which do not have a serial port, or VOX available to key the rig. It can be keyed manually by activating the switch.

3.2.4.3 FSK Control and Indicator - The rig can be operated in RTTY mode using AFSK modulating the audio channel. This is available from many software packages.

Some rigs have built in FSK generation capability, and special filters used in RTTY mode. These rigs expect a pulsed signal to drive it at the baud rate (normally 45.5 baud). To operate in this mode, a separate FSK signal must be created to feed into the FSK port on the rig. This is provided by the PC control signal DTR, resistor R2, Opto-Isolator U2 and the yellow half of the dual display LED1.

Diode D4 is provided across the FSK output in case the signal is tied to an inductive load like a relay coil.

This circuit can also be used to drive the key input of a rig for CW operation, if the rig can not be keyed using the PTT control line in CW mode. Rigs normally have a narrower filter for CW operation than for SSB operation, so CW operation using the PC and the interface is usually more effective if the rig is operated in CW mode.

3.3 A Note of Caution About Driving the Rig with Opto-Isolators.

Most rigs manufactured today allow the drive of the PTT line with a fairly low current driver. Some older hybrid tube/solid state rigs used fairly hefty relays in the PTT circuit with currents in the 100 ma. range or more. There is not enough current drive provided by the opto-isolator for these rigs, and this interface should not be used with them. If you have doubts about the drive level needed, use a VOM in the DC current mode and measure the current when you activate the PTT of the rig with the meter. If it measures more than 100 ma. do not use this design. An intermediate relay must be installed to provide the output drive.

4 Ordering Parts

4.1 Sources - The parts list for the interface is provided in the table 4.1 below.

The Printed Circuit Board, Legend Overlays and this Manual are available from::

Discovery Bay Computing
253 Snagstead Way
Port Townsend, WA 98368

Phone (360) 379-4042
Email: discobay@waypt.com

Most of the other parts are available from:

Mouser Electronics

Phone 1-800-346-6873

www.mouser.com

In this case, the Mouser part number is provided for each part. The online ordering system at Mouser.com allows lookup of the part in the catalog, and spec sheets for the parts. Some of these parts, such as resistors, capacitors, and diodes could be ordered from other sources if you choose. Other parts are selected for their physical size and configuration to match the PCB design. These parts are marked with an asterisk (*). Parts so marked should be ordered from Mouser unless you are sure you have a compatible part. Every effort has been made to ensure that these parts selected are in supply and that the part numbers are correct.

4.2 Alternate Sources - There are some parts that are available from other sources, possibly at better pricing. These parts are shown with a double asterisk (**) and in particular include the ready made shielded stereo audio cables. Radio Shack has these at better prices than Mouser. If you have a local Radio Shack store check out their pricing on these components Radio Shack part numbers and catalog references are also provided for these parts.

Another good source for connectors is Universal Radio - see <http://www.universal-radio.com/index.html>

4.3 Parts List - The parts list is broken down into the following categories:

- Design and PCB Package
- Circuit Board Assembly, Chassis & Serial Port Cable components
- Audio cables
- Rig control cable
- Rig microphone or accessory port mating connector

The only component that you will have to track down yourself, is the matching rig microphone or accessory connector. Radio Shack is a good source for these connectors.

4.3.1 Design and PCB Package - Source Discovery Bay Computing

Qty	Flag	Item	Part Number
1	*	Interface design package	100114

4.3.2 Circuit Board Assembly Components - Source Mouser Electronics

Qty	Flag	Item	Part Number
2	*	3 cond 1/8" mini jack rec. pcb	161-3507
1	*	3 cond 1/8" mini jack rec. pcb w/ switch	161-3508
1	*	3 cond 2.5mm jack rec. pcb	161-2502
1	*	RJ45 jack, pcb mounting	571-5577851
2	*	Transformer, 1:1 audio 600 ohm	42TL016
2		Resistor, 1/4 watt 5% 51 ohm	30BJ250-51
1		Resistor, 1/4 watt 5% 100 ohm	30BJ250-100
1		Resistor, 1/4 watt 5% 1.0k ohm	30BJ250-1.0k
3		Resistor, 1/4 watt 5% 2.2k ohm	30BJ250-2.2k
1		Resistor, 1/4 watt 5% 4.7k ohm	30BJ250-4.7k
1		Resistor, 1/4 watt 5% 10k ohm	30BJ250-10k
1		Resistor, 1/4 watt 5% 1M ohm	30BJ250-1.0m
2	*	Potentiometer, 1k audio taper 9mm snap in	317-2080-1k
2		Capacitor, .0047 uFd 50v	140-50P5-472K
1	*	Capacitor, 1.0 uFd 50v	5989-100V1.0
2	*	Capacitor, 10 uFd 25v Tantalum	581-TAP106K025SCS
4	*	Diode, 1N4148	583-1N4148
1	*	Switch, mini-toggle SPDT on-off-on pcb	612-100-C1121
2		Opto-isolator, 4N33 DIP	512-4N33
1		Transistor, NPN, 2N3904	512-2N3904
1	*	Diode, Dual LED T 1 1/4 Red / Yellow	512-MV5337
2		Knob, 1/4" shaft, 0.75" dia.	45KN018
1		Audio Transducer AT-20	665-AT-20K
2		Standoff, nylon, male/female 0.5 inch	561-MF440-50
2		Standoff 0.25 inch aluminum, round	534-2025
2		Screws 4-40 0.25 in beveled	561-F440.25
2		Rubber bumpers .25 x .50	534-720
2		Bumpers, tapered sq .23 x .50	517-SJ-5018

4.3.3 Plastic Box Enclosure - Source Mouser Electronics

Use these parts if you use the plastic box enclosure instead of the Altoids box.

1		Box, plastic project 4.19x2.74x1.57	400-5053
1		Cover plate, aluminum for 400-5053 box	400-7053

4.3.4 Serial Control Cable

1		Cable, 2.5mm stereo to stripped wire 6'	172-2204
1		DB9 female connector, solder pot	156-1309
1		DB9 cover	156-2009

4.3.5 Audio Cables - Source Mouser Electronics (M) or Radio Shack (RS)

Qty	FlagItem	Part Number	Source
3	Cable, 6', Shielded stereo audio 1/8" mini	172-2208	M
	or		
3	Cable, 6', Shielded stereo audio 1/8" mini	42-2387	RS

Note: qty above assumes that the connection to the rig is via the microphone and a line out or speaker out via a 1/8" connector. **If the rig is interfaced using an accessory connector for both transmit and receive audio, change above quantity to 2.**

4.3.6 Rig Control Cables - Source Mouser(M) or Radio Shack (RS)

Qty	FlagItem	Part Number	Source if not Mouser
1	18 inch, 4 twisted pair (8 conductor) CAT 5 type cable with RJ45 connector on one end, the other end connects to the rig microphone or auxiliary matching connector. Here are some ways to procure this cable:		
1	Category 5 patch cable 3 foot cut the patch cable at the required length or Go to your local radio shack store and have them make up a cable with CAT 5 cable and the RJ45 connector. They will usually do it for much less than the above price.	571-2191973	M

4.3.7 Rig Microphone or Accessory Connector - Source Mouser or Radio Shack

Qty	FlagItem	Part Number	Source
	The type of connector used for the microphone varies from transceiver to transceiver. Below are some sources for connectors. You will need (1).		
	Some microphone connectors		
	Connector, 8 pin, microphone	274-025	RS
	Connector, 4 pin, microphone	274-001	RS
	Some accessory type connectors		
	Connector, plug, 5 pin, DIN	274-003	RS
	Connector, plug, 8 pin, DIN	274-026	RS
	Connector, plug, 5 pin, DIN	171-0275	M
	Connector, plug, 6 pin, DIN	171-0276	M
	Connector, plug, 8 pin, DIN	171-0278	M
	Connector, plug, 13 pin, DIN	0954	Universal Radio
	(note this is a hard to find part see http://www.universal-radio.com/catalog/parts/dinconn.html)		
	Connector, plug, 6 pin, Mini-DIN	171-2606	M
	Connector, plug, 8 pin, Mini-DIN	171-2608	M
	Connector, plug, 9 pin, Mini-DIN	171-2609	M

5 Assembly

The assembly of the interface is done in four sections; PC board, cables, top panel, and enclosure. They should be done in the order above, since the finished board is used for checking the cutout of enclosure hole patterns, and for alignment of installing the panel overlays.

5.1 Printed Circuit Board (PCB) Assembly:

5.1.1 Polarized Components - There are some components which are polarized or keyed, so attention must be paid to the orientation of the components that go on the board. These polarized/keyed components will be marked with ** in the component stuffing chart, figure 5.1.3.

5.1.2 Components Requiring Special Mounting

There are four component types which are installed in a special manner. These are the LED, the Switch, the Audio Transducer, and the Potentiometers. The LED is mounted such that the top of the “flange” is 0.5” above the top of the circuit board. Also, the LED is polarized. The “flat” side goes toward the top of the board. The switch is mounted all the way down on the board. The lower nut is adjusted such that the top of the nut is 0.5” from the top of the board. The potentiometers are mounted on the top side of the board, with the shafts pointing up. The potentiometers are NOT pushed all the way down on the board. See figure 5.1 for correct spacing. The Audio Transducer is the last component to be mounted on the board, and should wait until testing of the rest of the board is complete. Refer to drawing 5.1, *Component Mounting*, for the dimension of component placements.

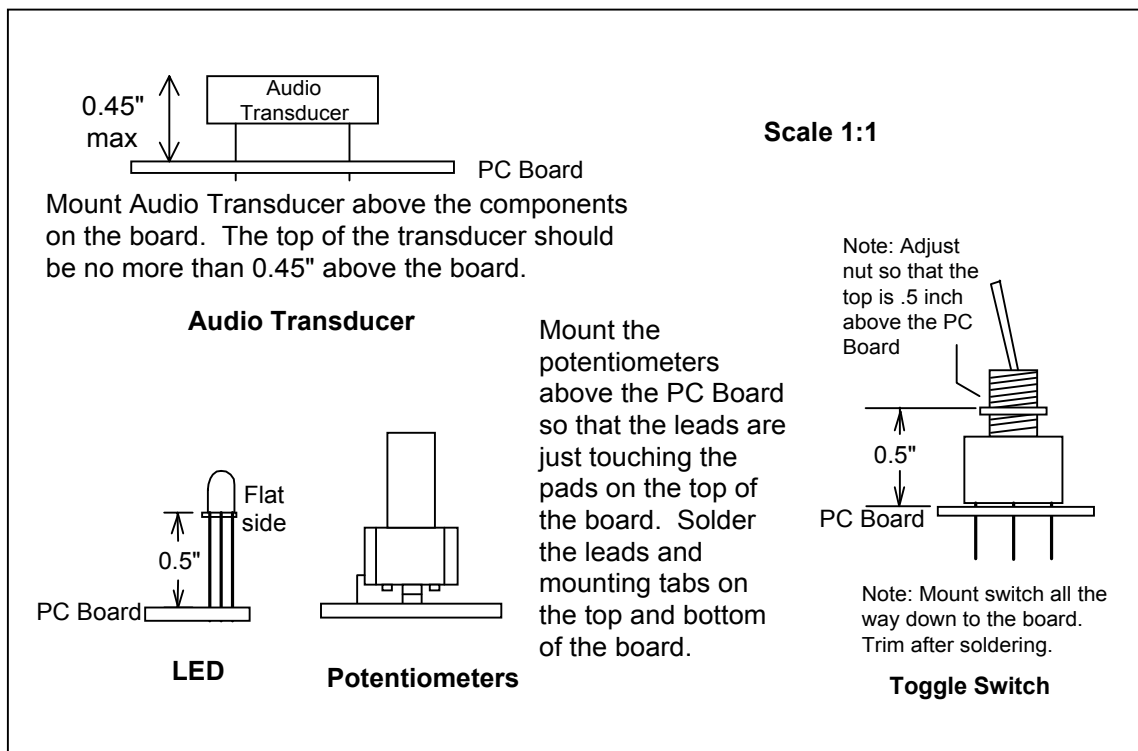

Figure 5.1 Component Mounting

5.1.3 Order of Assembly - A drawing of the component placements for the board is shown in figure 5.2, *Printed Circuit Board Assembly Diagram*, below. The list of components stuffed in the board and the order of assembly of the components is shown below.

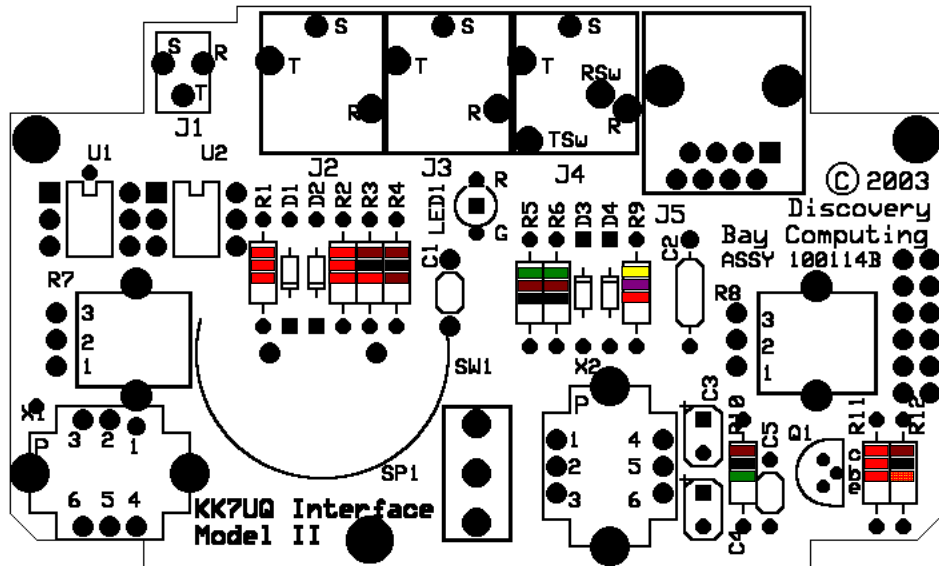

Figure 5.2 - Printed Circuit Board Assembly Diagram

Connectors

J1	**	2.5mm stereo connector (3 pins)
J2 J3	**	3.5mm stereo connector (3 pins)
J4	**	3.5mm stereo connector with switches (5 pins)
J5	**	RJ45 Jack

When mounting the four stereo connectors, ensure that the front of the body of the jack is flush with the edge of the circuit board. Orient the connectors so that they are square to the edge of the board.

Integrated Circuits

U1 U2	**	4N33
-------	----	------

The Opto-Isolator integrated circuits are marked with a *notch* at the top edge, *or a dot* at the upper left hand edge, it should be aligned as shown on the silk screen of the PCB. Solder U1 and U2 to the board

Potentiometers

R7 R8	**	Potentiometer, 1k ohm audio taper
-------	----	-----------------------------------

The potentiometers are mounted on the top side of the board, with the shafts pointing up. The potentiometers are NOT pushed all the way down on the board. See figure 5.1 for correct mounting.

Transformers

X1 X2 ** 1:1 Audio transformer 600 ohm

Audio transformers are **marked on one side with a "P"** (Primary) these should be aligned with the "P" on the circuit board silk screen. Solder and trim the leads. Solder the mounting tab to the board.

Transistor

Q1 ** Transistor 2N3904

Q1 is mounted with the flat side pointing right per the board silk screen. Position the transistor about 1/8" above the board.

Resistors

R1, R2, R11	2.2k ohm ¼ watt Red Red Red
R3	1.0k ohm ¼ watt Brown Black Red
R4	100 ohm ¼ watt Brown Black Brown
R5, R6	51 ohm ¼ watt Green Brown Black
R9	4.7k ohm ¼ watt Yellow Purple Red
R10	1 meg ohm ¼ watt Brown Black Green
R12	10 k ohm ¼ watt Brown Black Orange

Resistors are mounted on pads 0.4" apart. Bend the leads down on each side of the resistor. Solder and trim the leads.

Diodes

D1 D2 D3 D4 ** 1N4148

The **cathodes are marked with a bar on one end**. They should be placed as shown on the silk screen. As an additional guide, the cathode end pad on the PCB is a square pad. Solder and trim the leads. Lead spacing of the diodes is 0.4 inch.

Capacitors

C1, C5	.0047 uFd disc ceramic 50v
C2	1.0 uFd ceramic 50v
C3, C4 **	10 uFd tantalum 25v the + polarity goes up

Solder and trim the leads.

Switch

SW1 ** Toggle switch, SPDT, On Off On

The toggle switch is mounted on the top of the board, and has a **keying slot** on one side which aligns with a washer on the top panel of the enclosure. It should be oriented with the slot toward center of the board. The switch is inserted all the way down on the board before soldering. Align the switch to be perpendicular to the board.

LED

LED1 ** Red / Yellow Dual LED, T1¾

The LED is polarized. The RED side is marked with the flat side on the base of the LED and goes toward the top of the board. See figure 5.1 for distance from the top of the board to the top of the flange on the LED.

Audio Transducer

SP1 ** Audio Transducer

The Audio Transducer is the last item to be installed. **It will be installed after initial testing of the board is complete.** For now, inspect the components that are underneath this item for proper value, orientation and solder quality. See also figure 5.1 for proper height for SP1.

At this point, the wiring of the interface board is complete, except for the Audio Transducer. This will be installed after the rest of the board has been checked for operation.

Once the external cables are built, the board can be connected and tested before it is put into the enclosure. BUT FIRST ... check your assembly work, paying attention to polarity of the components, and quality of soldering. Then it is a good idea to clean the bottom of the board with a flux remover such as Radio Shack "Tronic Kleen".

The completed assembly at this point should look like this (without the audio transducer).

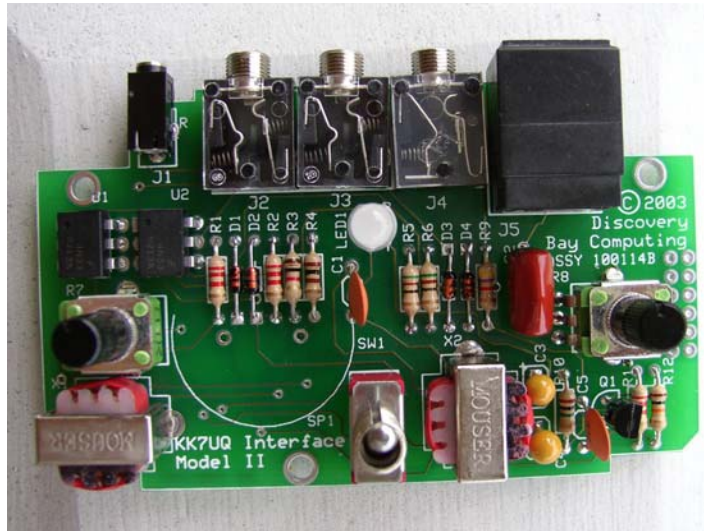

After test of the unit, the audio transducer should be installed. It will look like this when completed.

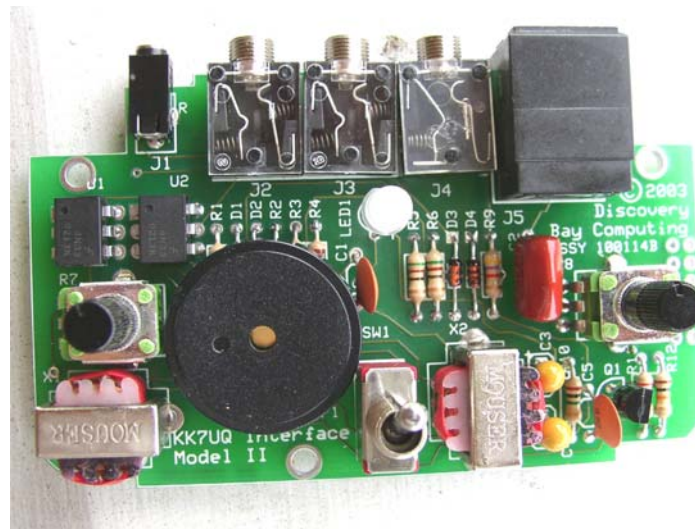

5.2 Cable Assembly

There are two cables that must be fabricated for use with the interface: the Serial Port Cable and the SSB Rig Control Cable.

5.2.1 Serial Port Cable - The Serial Port Cable is a 6 foot cable with a DB9 (female receptacles) on the PC end, and a three conductor 2.5mm stereo plug on the interface end. The two control signals RTS and DTR are carried on this cable. See Figure 5.4 for details on construction of this cable. All parts for this cable are included in the parts list.

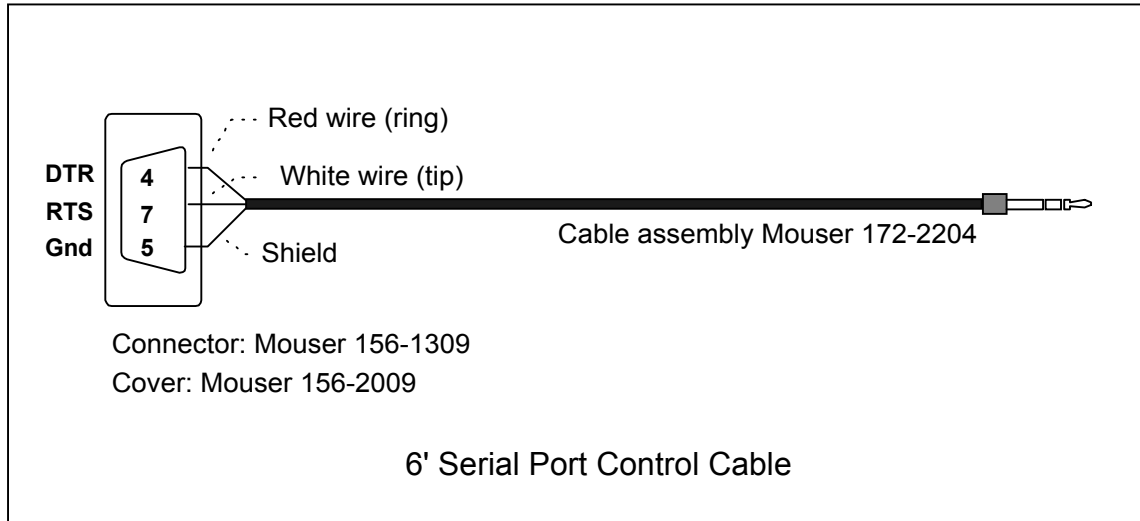

Figure 5.4 Serial Port Control Cable

5.2.2 SSB Rig Control Cables - The SSB Rig Control Cable is a nominally 18" cable which connects the interface to the SSB Rig. There is an RJ45 8 wire connector on the interface end. The rig end has a connector which mates with either the microphone jack or the Accessory jack. This cable can be built in two forms.

The first form is one that mates with the microphone jack which carries the audio and the PTT controls to the rig. Unless the microphone connector also provides audio output signal, the audio out from the rig is connected to the interface by a separate shielded audio cable.

The other form is intended to connect to the rig Accessory Port, and carries both audio to the rig and receives audio from the rig and sends it to the interface. The PTT (and FSK) controls are also carried on this cable.

The choice as to which form to use depends upon the rig. If there is an accessory port, you will probably want to use it. There is only one cable required, and you can leave your microphone connected if you want to. An example of use of the accessory port are shown in figure 5.5 below. This example uses the Accessory Port of the Icom 706 MKII Transceiver. Note that this cable incorporates the FSK signal for RTTY mode.

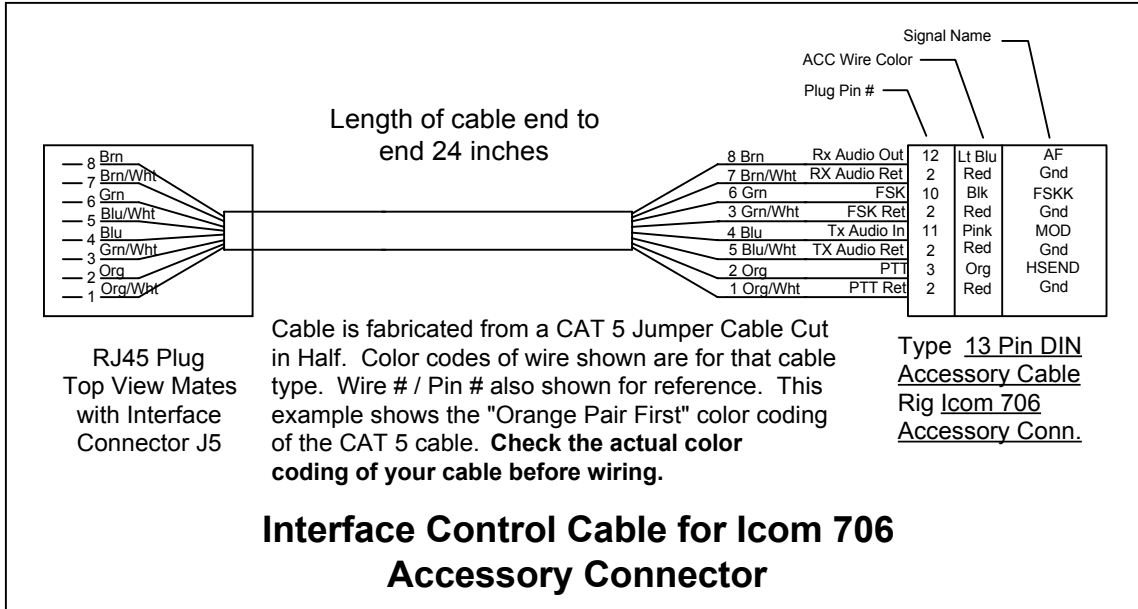

Figure 5.5 SSB Rig Control Cable Connected to the Accessory Port

If there is no accessory port, use the microphone input for the audio to the rig and the PTT, and provide a separate audio cable for the audio out from the rig to the interface. You will have to decide which audio output to use for this second cable. If there is a "Line Out" port, it is probably the best since the output is usually independent of the AF Gain control. Its level out is usually controlled only by the RF Gain control.

If there is no "Line Out" port, you can use the external speaker output, or the headset jack. These two audio outputs do have a problem, since use of either one cuts off the sound from the speaker of the rig. To get around this, you can use a "Y" connector and use one side for the rig audio / interface cable, and the other to drive an external speaker or a headset. Examples of cable which connect to the microphone connector for the Kenwood TS570 is shown in figure 5.6 below. Blank worksheets for use with your rig are shown in figure 5.7 below.

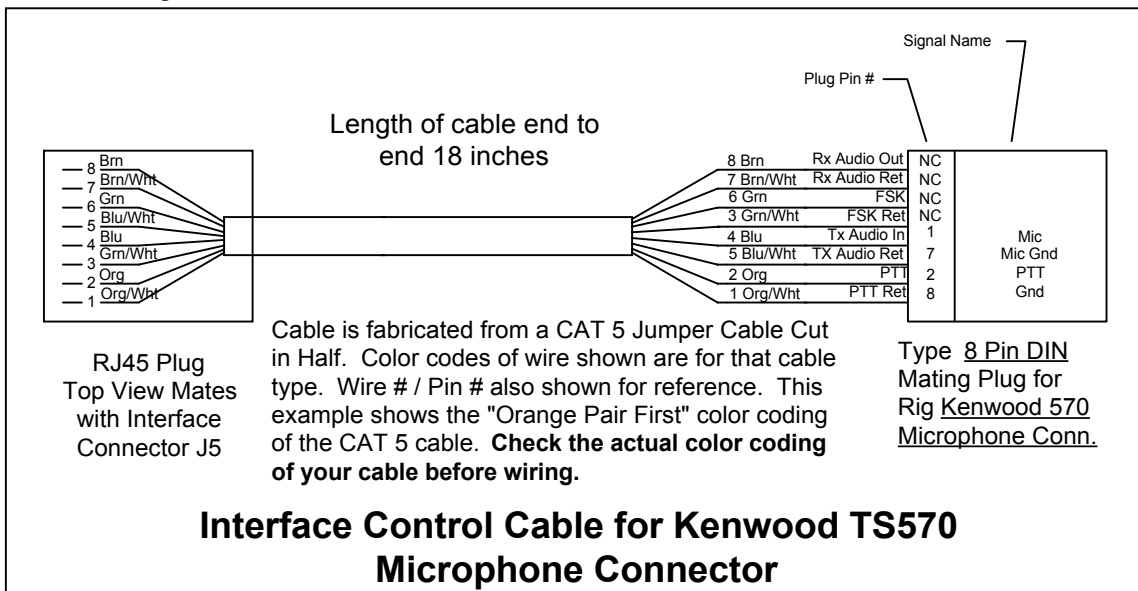

Figure 5.6 SSB Rig Control via the Microphone Connector

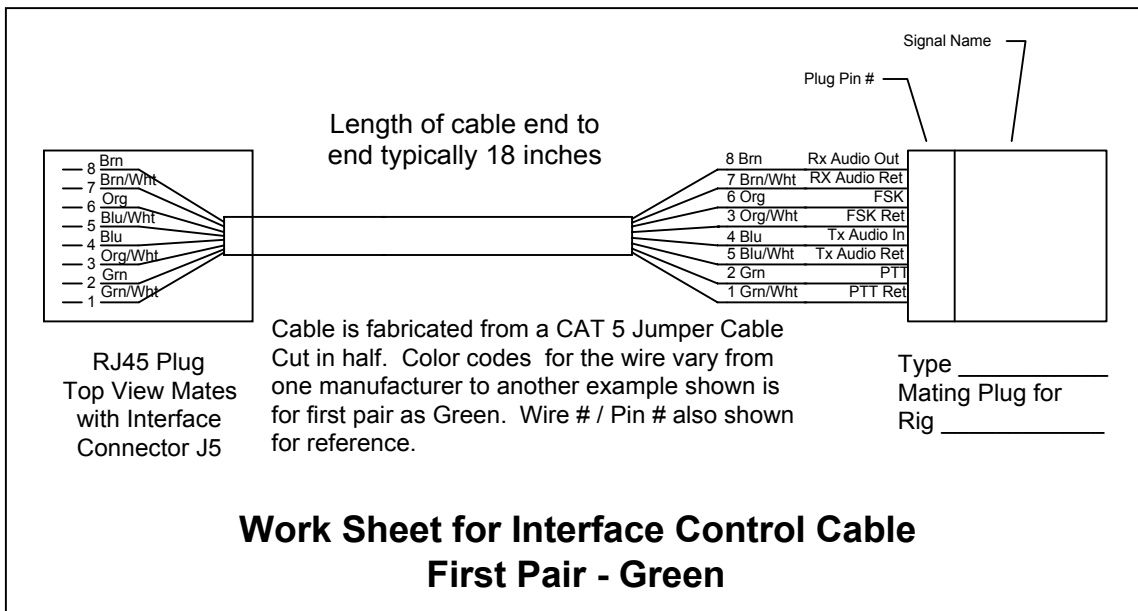
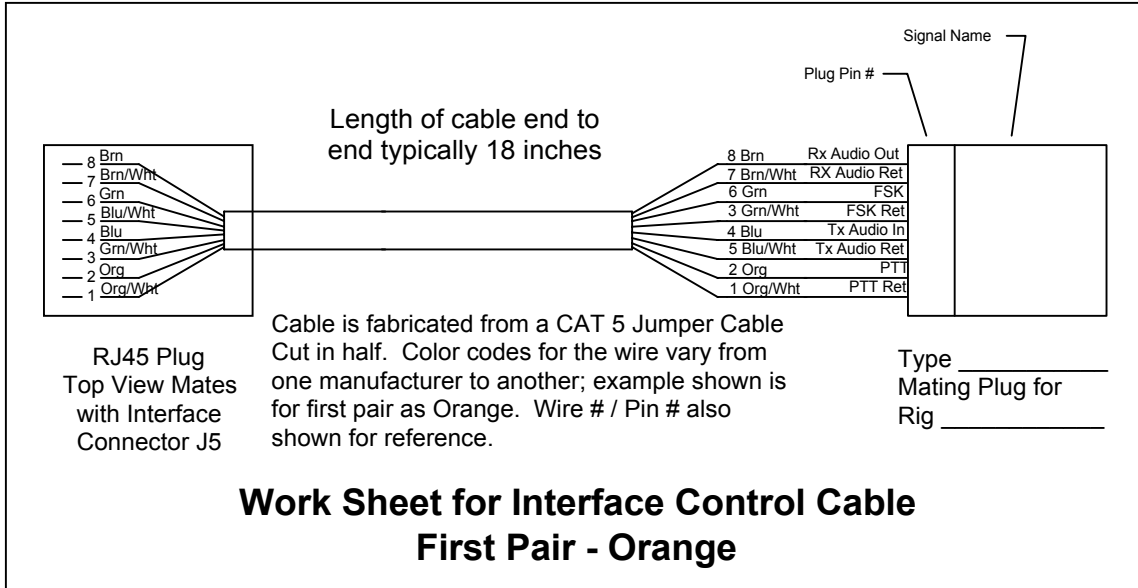

Figure 5.7 Work Sheets for Interface Control Cable

Work sheets for the Rig Interface Control Cable are shown above. **The color coding of “standard” CAT 5 cable is not well controlled - there seem to be two prevalent color codes used: Orange pair first, and Green Pair first.** Check the cable that you have to be sure of the type you are using. **If in doubt, do a continuity check with a multimeter to determine the color coding of your cable before wiring your cable.**

5.3 Enclosures

5.3.1 Altoids ® Box Enclosure

This version of the enclosure uses the Altoids ® box. This box is built of fairly thin material. Drilling holes requires some care to avoid ragged edges. You will find it much easier to drill the holes under size and increase the size with a countersink bit on the drill. This results in smoother edges and less “drift” of the bit.

Using these techniques, you should get good results working with this box. If you prefer a slightly larger box, the larger Eagle Plastics box described in 5.3.2 is a little easier to drill and finish.

5.3.1.1 Top of the Box

Leave the top on the box. The top of the box is drilled per the template shown, and the completed interface board is attached to the bottom of the lid using standoffs mounted on the underside of the lid, and the switch of the board with a nut positioned to make the board parallel to the lid. The lid and board will hinge down over the bottom of the box.

Drill Template - the drill template for the top is shown in figure 5.6 below. A copy of this template is provided with the interface kit, which can be cut to size and taped to the top of the Altoids box previously removed from the bottom. Once it is aligned, secure the template in place with clear tape. Use a sharp, pointed tool like an awl, a small center punch, or the tip of the exacto knife blade to mark the center of each hole to be drilled. Drill a 1/16” pilot hole for all hole positions. Once the pilot holes are drilled, remove the template and increase the size of the hole to the specified size using a small drill than the specified size and enlarging with a countersink bit on the drill. This results in clean, round holes.

Particular care should be taken with the two 1/8” mounting holes. Start with the 1/16” bit then enlarge the hole until the 4-40 screw fits snugly. Using the countersink bit also dimples the top slightly which is the desired effect - you want the screw to fit fairly smoothly across the top.

Note: The top washer for the switch is not used in this configuration, so no hole is drilled for the tab of that washer.

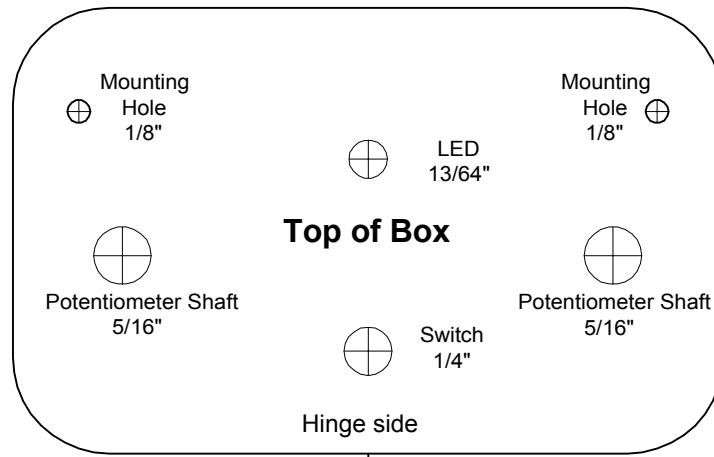

Figure 5.6 Altoids ® Cover Drill Templates

5.3.1.2 Bottom of the Box

Cut out the template using scissors. Fold it back along the fold line shown, with the fold going under the box. Use the alignment lines to center the template on the bottom. Then tape the template in place with

clear tape. Draw scribe lines into the metal using the tip of the exacto knife for the two vertical cuts. Also put in scribe lines along the bend line shown. Remove the template.

Back of Box (non - hinge side)

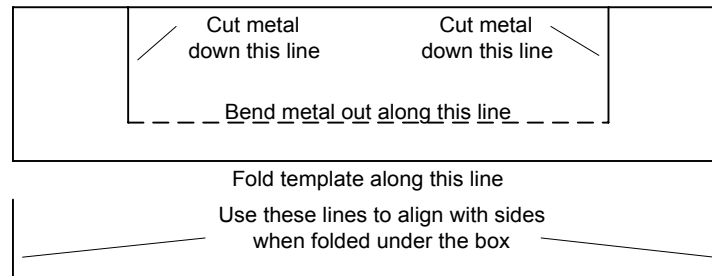

Figure 5.7 Altoids ® Box Back Panel Template

The back panel will be cut away on the side without the hinge. Two cuts are made down the lines shown on the template Figure 5.7. The metal is bent outward from the box along the bend line shown on the template. Trim off most of this metal near the bend line, leave about 1/10th inch. Then fold the metal back into the box and crimp it down along the lower edge. This double thickness stiffens the box and removes the sharp edge. When the unit is assembled, the circuit board swings into place with the bottom of the circuit board along the folded edge.

Now assemble the circuit card into the lid using the standoffs and 4-40 screws. If you try to fit the board assembly on the standoffs, the black RJ45 connector will interfere with the lip of the lid. The metal on the lip must be removed to allow the connector to protrude through the side. Scribe two lines in the lip along the side of the connector, right up to the top of the lid. Cut along these scribe lines, and fold it out away from the box. Cut near the top edge, leaving about 1/10th inch exposed. Fold the exposed part back into the box and crimp it on the underside of the lid. The circuit card assembly should now drop in place. Secure the circuit card to the nylon standoffs with the 1/4" aluminum standoffs. Then adjust the nut on the switch assembly until the lid rests on the nut and the board is parallel to the lid top. The lid should now swing down into the bottom of the box. The aluminum standoffs will touch the bottom of the box and the circuit board should come to rest along the folded metal at the back of the box. With the lid in place, the connectors should not touch any metal of the box. Make adjustments as necessary.

5.3.1.3 Panel Overlays - the overlay for the top cover carries the legends and identification of all functions on the panel. It is produced with a photo printer onto photo quality paper, hence it is thicker than normal printer paper and has a glossy finish. A reproduction of the overlay is shown below in figure 5.8. The actual overlay is provided in the interface kit. The overlay is made to fit over the gold oval outline on the top of the Altoids box.

Cut the overlay on the outer edge of the gold oval on the print. Then, with the exacto knife, cut the white circles out of the LED and Switch holes in the center of the overlay. The PTT/FSK hole is shown with a circle inside a larger heavier "ring". Cut along the thin line of the circle. This hole will be a friction fit on the LED, and is slightly smaller than the hole in the panel. The other holes will be covered by either the knobs or the switch nut, so any "ragged edge" will be covered by this hardware.

Once the overlay has been trimmed, do a sample fit over the top panel. Align the panel and the overlay with the LED hole and the switch hole. The easiest way to do this is to use a sharp, round pointed tool like an awl or a ball point pen pushed through each hole far enough to just fill the white portion of the hole. Once these two holes are punched, the overlay should drop right over the corresponding holes on the top plate. Do final adjustment of the gold outline on the Altoids box until you are satisfied that you have a good fit.

Apply spray adhesive on the back of the overlay, let it set until tacky for a minute and then carefully position it to align with the holes on the top of the box. Use the PTT/FSK hole as the registration point.

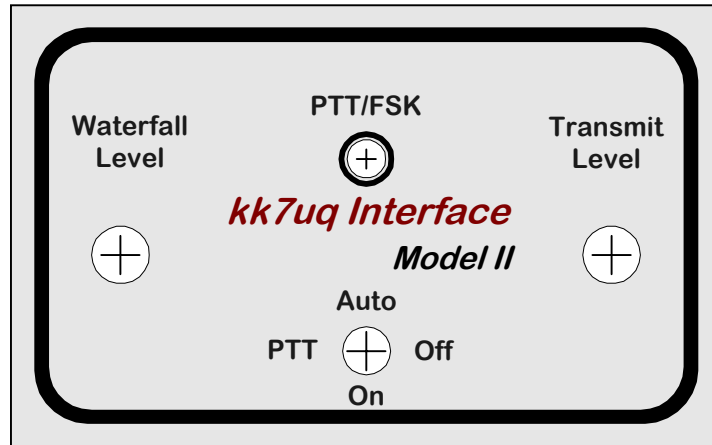

Figure 5.8 Panel Overlay

A good adhesive is Elmer’s “Craft Bond Multi-Purpose Spray Adhesive”. Other contact adhesives suitable for mounting photographs in albums will also work. Follow the instructions on the can. Let the completed assembly dry for a few minutes, then remove the excess overlay paper around the edges of the holes with a sharp exacto knife.

Overlay for the Bottom of the Box

The Overlay for the Bottom of the Box is shown in Figure 5.9. Cut it along the outer edge of the oval border. It is placed on the bottom of the box, and is aligned with the connectors at the back of the enclosure. Spray the backside with adhesive, let the completed assembly dry for a few minutes, then place it on the back with the legends aligned under the connectors.

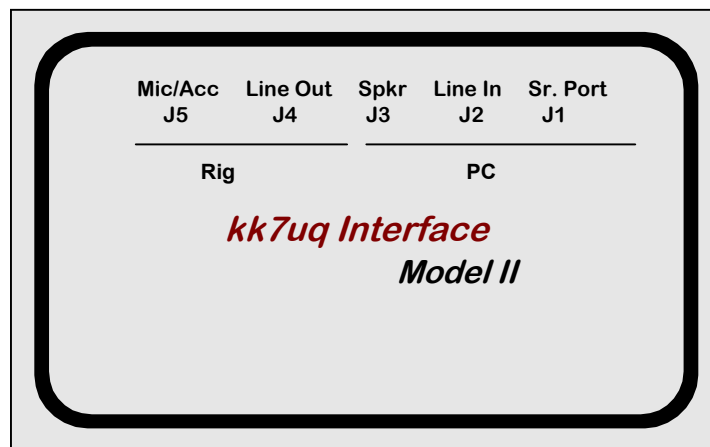

Figure 5.9 kk7uq Interface Model II Bottom Overlay



Figure 5.10 kk7uq Interface Model II

A photo of the completed unit, with a circuit board assembly shown in front of the unit.

5.3.2 KK7UQ Model II - Eagle Plastics Enclosure

You may prefer to build the enclosure using a larger, plastic box from Eagle Plastics. This section describes the method of drilling and fitting this option.

5.3.2.1 Cover Plate

5.3.2.1.1 Drill Template - the drill template for the cover plate is shown in figure 5.11 below. A copy of this template is provided with the kit. This template will be taped to the blue protective plastic on the top of the blank aluminum plate supplied with the enclosure. The four mounting holes are already drilled in the cover plate, and the template should be aligned over these holes. Once it is aligned, secure the template in place with clear tape. Use a sharp, pointed tool like an awl, a small center punch, or the tip of the exacto knife blade to mark the center of each hole to be drilled. Drill a 1/16" pilot hole for all hole positions. Once the pilot holes are drilled, remove the template and drill the actual hole size as shown below. Clean the rims of the holes by hand, using a larger drill bit or a counter sink bit to clean the edges. Once the holes are drilled and cleaned, remove the blue plastic from the top of the plate.

Note: Two washer tab holes are shown on the template. Normally only the top one is used, the second one is provided in case the switch was put in the other way around on the PCB. Instead of trying to remove the switch, just insert the washer with the tab down and use the bottom hole. The holes are covered by the overlay, and the hole in the overlay is created when the washer is installed the first time.

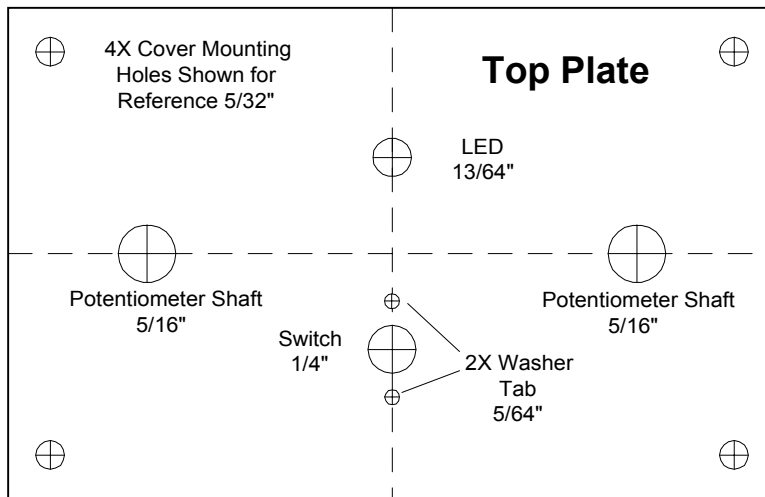

Figure 5.11 Cover Drill Templates

5.3.2.1.2 Panel Overlay - the overlay for the top cover carries the legends and identification of all functions on the panel. It is produced with an ink jet printer onto photo quality paper, hence it is thicker than normal printer paper and has a glossy finish. A reproduction of the overlay is shown in Figure 5.12. The actual overlay is provided in the interface kit. The overlay is made slightly larger than the panel size itself. This is to provide a trim area after the overlay is glued to the panel.

The overlay will be installed over the drilled cover plate and glued down. After the glue has dried, the holes for the components will be cut with a sharp exacto knife to match the holes in the plate.

Once the overlay has been trimmed, do a sample fit over the aluminum panel. Align the panel and the overlay at the four mounting holes. The easiest way to do this is to use a sharp, round pointed tool like an

awl pushed through each hole far enough to just fill the white portion of the hole. A ball point pen will also work for this. Once the four holes are punched, they should drop right into the aluminum panel. Verify that the holes in the overlay are positioned over their respective hole in the panel. The only critical hole for alignment is the PTT Hole.

Before you apply the adhesive to the back of the overlay, you may want to build a jig to help keep the overlay in alignment while the overlay with adhesive on the back is being lowered onto the panel. A description of this jig is found in section 5.3.2.1 below.

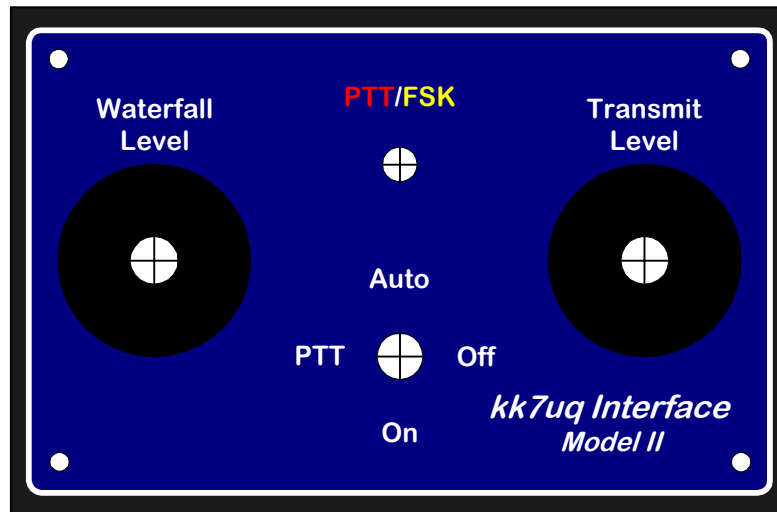

Figure 5.12 Panel Overlay

5.3.2.1.3 Overlay Alignment Jig - this jig is a piece of 4" x 6" x 1/2" wood with 1" roofing nails inserted at the location of the each of the four mounting holes of the aluminum panel. If no wood is available, use a piece of cardboard.

To make the jig: Place the bare panel on a piece of wood, and drill holes in the wood at the location of the four mounting holes on the panel. Use a 1/8" drill. Keep the drill as vertical as possible. Turn the wood over and counter sink the holes on the bottom side so that a 1" roofing nail can be inserted through the hole and the head will be countersunk into the board. The nail head should stick out on the top side about a 1/4 to 1/2 inch. With nails inserted in all four holes, turn the wood back to the original position and ensure that the plate is centered on the holes. Then take the overlay and slide it down over the nails. The "cylinder" made in the overlay paper on the four mounting holes should just slide into the gap between the nail and the hole in the plate. When you are sure that the overlay and panel align properly, remove the overlay and apply adhesive to the back of the overlay with spray on contact adhesive, per the instructions on the can. Then slide the overlay along the nails and drop the overlay in place on the panel. Smooth out the overlay from the center toward the outside in case there are any bubbles in the surface.

A good adhesive is Elmer's "Craft Bond Multi Purpose Spray Adhesive". Other contact adhesives suitable for mounting photographs in albums will also work. Follow the instructions on the can.

Let the completed assembly dry for a few minutes, then remove the panel/overlay from the jig and turn the panel face side down on a surface that you can cut on. Remove the excess overlay paper around the edges of the panel with an exacto knife. Cut the holes for the four components with a sharp exacto knife. The panel/overlay should be ready for use at this time.

Note: if you are unsure about being able to apply the overlay with the adhesive on it, the overlay can be used without the adhesive, it will be held in place fairly well by the four mounting screws and the switch washer and nut.

5.3.2.2 Enclosure

The enclosure is a black plastic box manufactured by Eagle Plastics. It is 4.1" W x 2.7" D x 1.6" H. Holes will be drilled and cut in the back of the box.

5.2.2.2.1 Drill Template - the drill template for the enclosure is show in figure 5.13 below. The actual drill templates are supplied with the interface kit. Cut out the template, along the dotted line. Fold the template along the top line, place this over the side of the enclosure. Line up the side edges of the enclosure with the lines at the top. Once aligned, tape the template to the box using clear tape. Mark the center of each hole to be drilled with a sharp pointed tool such as an awl, or the tip of the exacto knife. Next use the knife to score through the template on the lines of the square cutouts for the 2.5mm jack and the RJ45 jack. After this has been done, you can remove the template and proceed with drilling and trimming the enclosure.

Be careful to drill the holes in the exact positions shown since they must align with the components of the circuit board.

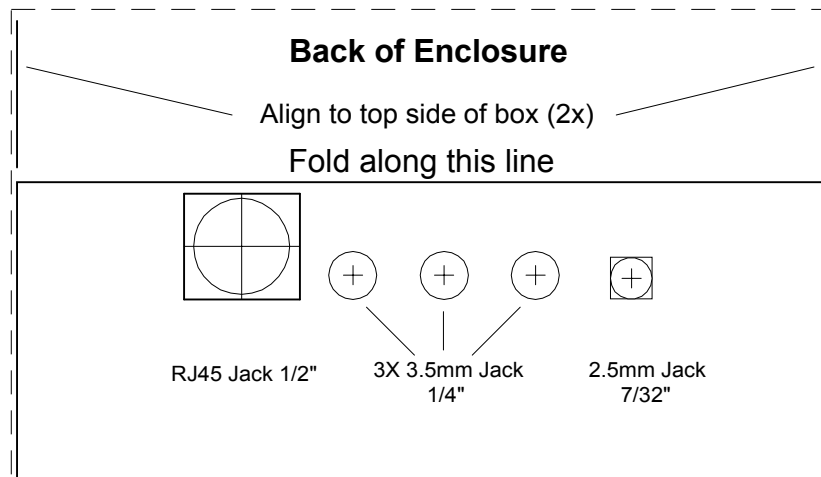

Figure 5.13 Enclosure Template

Do a trial fit of the assembled board through the holes in the enclosure. The assembly should slide in and out easily. The holes for the 3.5mm stereo connectors may need to be beveled to allow the knurled nuts to tighten onto the connector. Once the enclosure fitting is done, snug all the knurled nuts down hand tight.

5.2.2.2.2 Assembly of the Parts

Then place the panel/overlay on the top, over the assembled board, with the LED and the switch sticking up through the overlay. There is a washer for the switch that goes over the top, with a "nib" on one side that will go through the overlay into the small hole in the panel beneath. Next align the washer over the switch onto the panel, and push it in place. A small hole will be punched by the washer in line with the alignment hole below. Apply the nut on the switch, and tighten down until snug. Screw in the four mounting screws in the corner. Install the knobs on the potentiometer shafts by turning the shaft full CCW and put the knob on in the "7 o'clock" position. Tighten the screws on the knob. All of these parts should be assembled before the legends are applied to the back of the enclosure.

Next, apply the legend overlays to the back of the enclosure, as described below. In the drawings below, the enclosure is shown in gray. This is done to make the legends stand out. The color of the actual unit is such that the black of the legend blends into the black color of the enclosure.

5.2.2.2.3 Legend Overlay Back of Enclosure - reproduction of the legend for the back side of the enclosure as applied to the back of the enclosure is shown in figure 5.14. This legend should be cut along the black edges of the periphery with no white showing. Apply adhesive to the back of the legend, carefully align it against the bottom edge of the round nuts on the phone jacks and smooth in place.

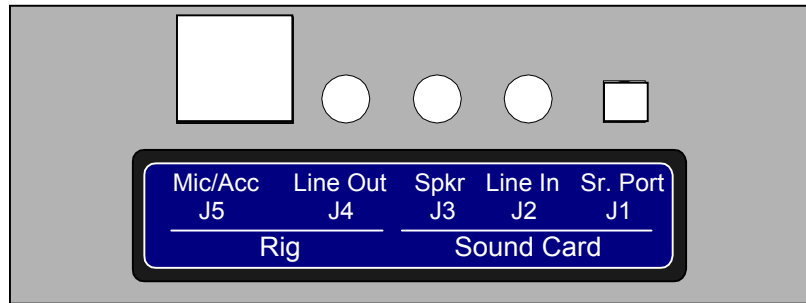

Figure 5.14 Legend Overlay Installed on Back of Enclosure

6 Software Sources - there are several sources for software to control digital modes using a sound card. Listed below are some of the popular current software offerings. The name of the program, the website where you can get free copies, log support, modes supported, the author, and comments about the software are listed below. For PSK31, the most popular software used today is MixW, followed by Digipan, Hamscope and WinPSK. All except MixW are free for amateur use. MixW has a one time user fee. New versions of these programs are released from time to time offering more features and better operation. Try several of these and decide for yourself which is right for your operation.

MixW <http://www.mixw.net/>

This program offers many different modes of operation, including PSK, MFSK, RTTY, Hellschreiber, SSTV, MT-63, Throb and CW. Excellent built in log, and contesting options.

Written by UT2UZ and UU9JDR.

Free demo, user fee for long term use. See their website.

Digipan <http://www.digipan.net/>

Has an internal log which supports name & qth pop on subsequent qso.

Has waterfall display that covers 4000 Hz

Monitors two channels

Modes supported: PSK31 (BPSK and QPSK)

Written by KH6TY, UT2UZ, UU9JDR

Hamscope <http://www.qsl.net/hamscope/>

Supports YPLOG

Has both waterfall and spectrum displays that cover 2800 Hz

Monitors two channels

Supports PSK31 (BPSK & QPSK); MFSK16; RTTY; CW

Written by KD5HIO

Hellschreiber <http://iz8bly.sysonline.it/>

Internal log

Supports PSK31 (BPSK & QPSK), Hellschreiber

Written by IZ8BLY

MMTTY <http://www.qsl.net/mmhamsoft/mmtty/>

Internal log, supports name and qth pop on subsequent qso, has contest mode

Supports RTTY

Considered the best sound card implementation of RTTY available as freeware, both Hamscope and Zakanaka use the MMTTY engine for their RTTY modes

Written by JE3HHT

MMSSTV <http://www.qsl.net/mmhamsoft/mmsstv/>

An excellent SSTV program for sound cards.

Written by JE3HHT

Stream <http://iz8bly.sysonline.it/>

Internal log

Supports PSK31 (BPSK & QPSK), MFSK8 and MFSK16 modes

Written by IZ8BLY

WinPSK <http://www.qsl.net/ae4jy/>

Supports PSK31 (BPSK & QPSK)

Written by AE4JY.

This was one of the first Windows supported PSK programs, the internal design have been licensed for use on the Hamscope and WinWarbler programs.

WinWarbler <http://www.qsl.net/winwarbler/>
Supports PSK31 (BPSK & QPSK)
Monitors three channels
Written by AA6YQ

W1SQLPSK <http://www.w1sql.com/>
A unique software package for PSK operation. This features a multi-qso display, useful for contests and for day to day operation.
Written by W1SQL.

Zakanaka <http://www.qsl.net/kc4elo/>
Has excellent support of the Logger program written by the same author.
Supports PSK31 (BPSK & QPSK), RTTY (using MMTTY engine)
Written by K4CY

7 System Setup and Test

This section describes the procedures for setting up your system to run sound card applications. You should select one of the programs in section 6 to use for testing and setup purposes. The examples given below are for the **Digipan** program. Additional information on setting up and using Digipan is found on the **KK7UQ web site: www.waypt.com/users/~discobay/** download a copy of “**Getting Started with Digipan**”.

For convenience, you may want to do the initial testing with the sound card out of it’s enclosure. **Be sure that the surface you place it on is not conductive!**

7.1 Load the Sound Card Program - Load the program and select **Configure/Personal Data** at the top of the screen. Enter your call sign, name and QTH in the panels.

Select **Configure/Serial** at the top of the screen. Select the number of the COM Port to be used for control of the interface. At the bottom, check RTS as PTT. DTR at PTT should be unchecked. Note: if you check both of these, the system will work fine, but the LED will show Orange instead of Red.

Before you hook up your interface and rig, try out the program to get familiar with the sounds coming from it and the operation of the macros. Set up the macros as suggested in the “**Getting Started with Digipan**” document.

7.2 Hook Up Your Rig - At this time, be sure that you have good ground connections to your PC the SSB rig and the tuner. Now, hook up the rig, interface and PC as shown in figure 7.1 below. Put the PTT control switch on the interface to the “Off” (center) position for initial tests. Be careful that you select the correct connectors on the sound card. The markings are etched on the metal and are hard to read. Refer to your sound card manual.

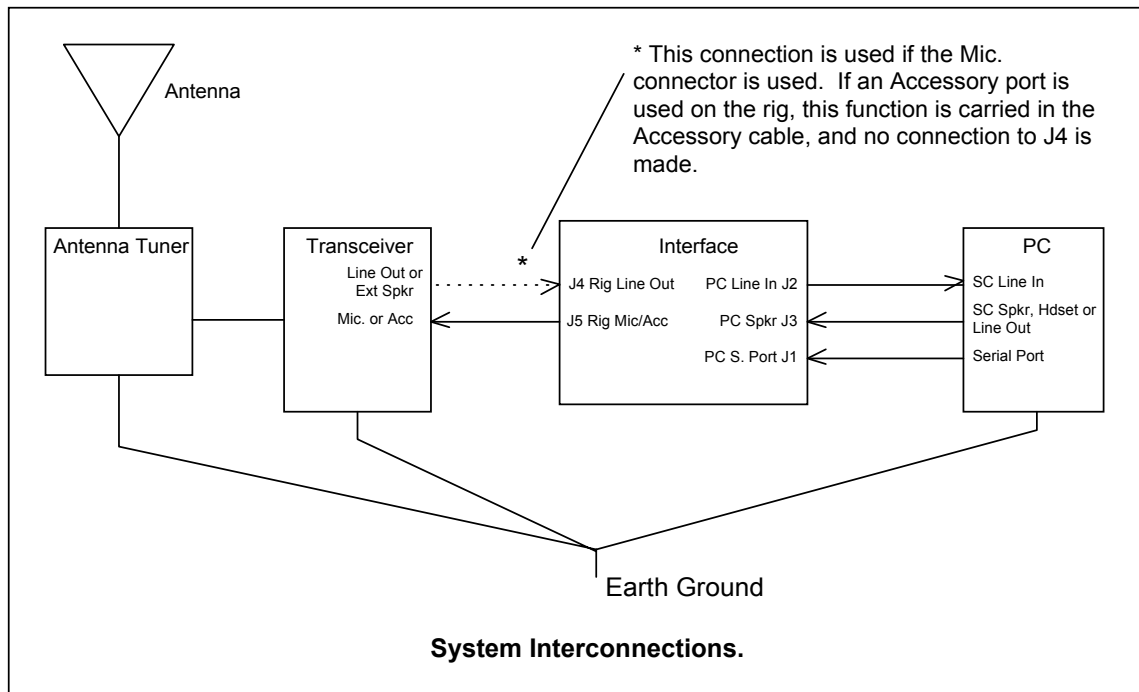

Figure 7.1 System Interconnections

7.3 Receive Settings - The next thing to do is to set up the Sound Card Receive control to receive sound only from the interface.

On the Digipan window, go to **Configure/Waterfall Drive** on the control bar at the top of the window. This will bring up a window to allow you to set up which sound sources will be selected for processing by the sound card. Select **Options / Properties**, set it to “Adjust volume for recording” and then click on all sources shown at the bottom of the panel. Click on “OK” and you will see the sliders for all possible sources for the sound card input. The display should look similar to the panel in Figure 7.2. Click “Select” ONLY on the “Line” slider. This is the one that the interface is tied to. At this time, you can select “Options” again and unclick all of the sources except the Line In if you want to. Set the slider for about the middle of the range.

Note: If you use the microphone input rather than line input to the sound card, check select on microphone instead.

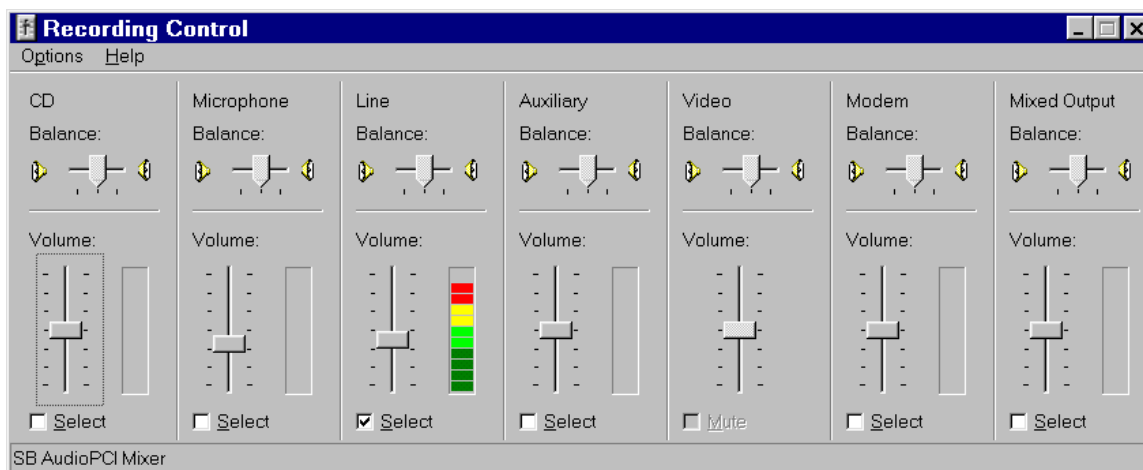

Figure 7.2 PC Rx Volume Control Panel

Set your SSB Rig to 14.070 USB (If your rig is LSB only, set it to 14.073 LSB). Listen for warbling tones on the frequency. If you hear tones, you should see signals on the waterfall display or the spectrum display. Set the Interface **Waterfall Drive** Control knob of the interface to about mid range. On the waterfall display, there should be a set of “tracks” going down the screen where a signal is being shown

If there are no signals on 20 meters, try 7.070 USB or 3.580 USB.

Set the Waterfall Drive level by rotating the **Waterfall Drive** knob on the interface. Full CCW should give you a black screen. Full CW should give you a yellow speckled screen. Set the knob position to the point where the screen background is blue, with only a few yellow speckles showing. Signals will appear as yellow vertical “tracks”. If the color of a signal track is red, reduce the level a bit. The red indication means that the input signal is saturating the sound card input.

If you do not see signal activity on the screen, but hear tones coming from your receiver, check your cable connections. If they are all right, inspect the PC board solder connections to be sure that all connections are soldered, and no shorts are apparent. Also be sure that the rig is set up to send audio from the output connector you have selected.

When you see signals on the screen, set the AFC button on the bottom of the Digipan screen. Then click on the center of a signal using the left mouse key. The top receive display should start printing data from the signal.

Other controls that affect the receive level are the RF gain of the receiver, and the receive volume control slider on the PC. The RF gain of the receiver can be used to reduce level of the signal sent to the sound card. The best use of the RF gain is to reduce levels when you are copying a very strong signal on the waterfall. Reducing gain helps reduce some distortion when the signal is driving the AGC of the receiver. You will see in the next section, that the IMD measurement can be affected by these strong signals.

Take some time to monitor signals and get a feel for the style of QSO used on PSK31.

7.4 Transmit Settings -

7.4.1 PC Transmit Drive Adjust - Go to the Digipan Screen, and select **Configure/Transmitter Drive**. The volume control panel for the sound card should appear. On that screen select **Options/Properties**. The Button for "Playback" should be set. In the panel at the bottom, click on all of the sources so you can view their settings. Click "OK". The full Volume Control panel should appear, and should be similar to the view in figure 7.3, below.

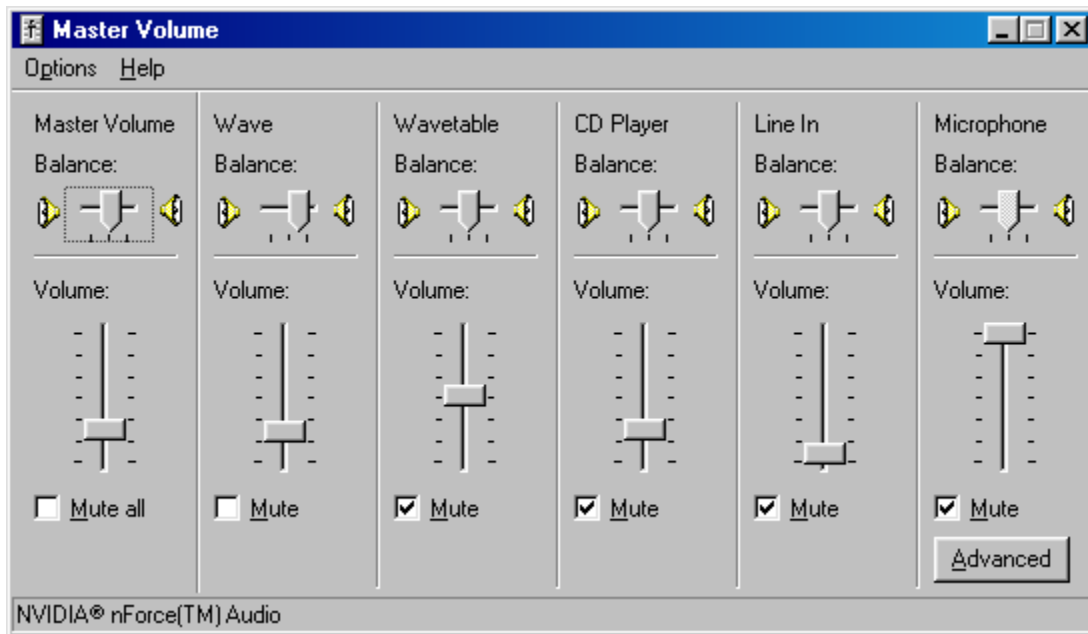

Figure 7.3 PC Tx Volume Control Panel

7.4.1.1 Mute Unused Sources - Check the Mute box on each panel except the "Master Volume Control", and the "Wave", as shown in the figure above. Muting all but the intended active sources ensures that other signal sources within the PC (like the mike on your monitor) can not be mixed in the audio you are using to modulate your rig. Also, external signals (like RF) that enter the sound card on these channels will not be amplified and be sent to the output.

The two controls not muted are: Wave, the control for the output level of the signal created by the Digipan program; and Master Volume control, the general output level control for all sources. The combination of the two determines the actual output level sent to the interface and the rig.

If you like, you can now go back to **Options/Properties** and unclick on the view selections for all but the Volume Control and the Wave Control. This provides a smaller window, viewing only the activated sources.

7.4.1.2 Set the initial PC audio level - Set the sliders on volume control to the positions shown in figure 7.2. About one third of the way on both sliders.

7.4.2 Getting Ready to Transmit - at this point you are ready to try transmit controls.

7.4.2.1 Reduce the rig power level and connect to a dummy load - It is a good idea to use low power and transmit into a dummy load during initial tests. Connect the transmitter to a dummy load, and set the rig output level control to around 5-10% of maximum.

7.4.2.2 Set the transmitter frequency - Set the transmitter frequency to USB, 14.070 MHz. The actual transmit frequency will be the combination of the SSB rig frequency (14.070), plus the audio tone created by the software (in the range of 200 to 2500 hz). The audio frequency is set by clicking on the waterfall at a particular audio frequency. If you are connected to an antenna, choose a point that doesn't have a signal on or near it.

7.4.2.3 Transmit Audio offset should be between 800 and 2100 Hz - The waterfall shows signals from about 200 Hz to 2800 Hz above the frequency set on the rig. When you transmit, you should limit yourself to a tighter range, using offsets between about 800 to 2100 Hz. There are two reasons for this. First, your rig has a transmit audio pass band that rolls off around 2100 Hz. Operating above that point will cause distortion. Second, don't go too low, as the pass band filter starts to roll off on the low end too. To work signals outside this range, move the rig frequency to get the desired signal in this limited range. Some software, like Digipan, has a waterfall width of about 4000 Hz, so be careful.

Some good news: There are some special single board transceivers built for PSK31 use which have a wider pass band, so check your manual to determine your particular rig's width. There are also some general purpose rigs, like the Ten Tec Pegasus, which have output audio pass band which can be set as high as 3900 Hz.

7.4.2.4 Set the Initial Transmit Drive controls - Set the Transmit Drive knob on the interface to full CCW. Leave the PTT switch on the interface in the **OFF** position. Leave the rig mic gain at it's normal setting for voice operations. Set the PC Volume control and the WAVE control at the levels shown in Figure 7.2.

7.4.2.5 Test the PTT - At this time, you should check that the PTT of the rig is operational. Place the rig in SSB/USB mode. Move the Interface PTT control switch to the **ON** position. You should see a transmit indication on the rig with no power output. Now, move the switch back to the **OFF** position. The rig transmit indication should go off. If there is no transmit indication, check that the rig cable is connected to the appropriate microphone or accessory port. Recheck the wiring of the rig cable.

Now try activating the PTT from the Digipan program. With the PTT switch in **OFF** position, click on the **Digipan T/R** button. The program should go into transmit mode, with the TX indication flashing on the lower part of the screen. The PTT/FSK LED light should show Red at this time. Move the PTT switch to the **AUTO** position and the rig should show a transmit indication. Click on the **Digipan T/R** button and the system should return to the RX mode.

Now you are ready to actually try transmitting a signal to the dummy load. Put the interface PTT switch to the **AUTO** position, and click on the **Digipan T/R** button again. You should see several things. The PTT LED on the interface should come on, and the rig TX indicator should come on. The interface **Transmit Drive knob** has been turned to the lowest position, so there should not be any power showing on the meter of the rig or antenna tuner. Now rotate the knob clockwise toward the half way position. You should see the power level increasing up to the level you set the output gain control.

Turn the knob back to the CCW position, and click on the **Digipan T/R** button to return to RX mode. The PTT LED should go off. Now you are ready to make the final adjustments of the transmit level controls on the PC and the rig microphone gain controls.

7.4.2.6 Power settings - A word about power settings. Your rig has been rated for SSB voice or CW operation, which run duty cycles of 50% or less. The digital modes are transmitting at nearly 100% duty cycle so you should not run your rig at more than one half the "rated" power level. If you have a 100 watt transceiver, run it at 50 W peak or less. Also, the PSK31 signals have multiple frequency content because of the modulation system. The audio path **MUST** be operated in the linear range when running PSK31. This means that you can **NOT** use the compression system, if you have one, and you should not operate at levels that use the ALC (automatic level control),

7.4.2.7 Adjust the Microphone Gain and the Wave level - Move the **Transmit Drive** knob back to CCW, and turn the SSB rig output level control to 100%. From this point forward, you will be adjusting the power output level with the interface **Transmit Drive** knob. **Monitor your output level and keep the actual output level at 50% or less.**

Turn on the transmit signal with the **Digipan T/R** button again and slowly move the **Transmit Drive** knob back toward the half way point. Use the peak reading setting on the power meter of the tuner or rig. Do not adjust the power above your half power point. If it is reached before the knob is at half way, reduce the audio level from the PC Volume control panel by moving the WAVE slider and the Master Volume sliders down. Until you can set the knob at half way with the output power level (peak) at 50%.

If you cannot reach the half power point when the knob is straight up, increase the audio level from the PC Wave control to bring it into range. The object here is to get the PC Wave gain settings to the point where there is adequate "head room" on the interface **Transmit Drive** knob. Once you have the levels adjusted, turn off the transmitter by clicking on the **Digipan T/R** button.

If you are unable to get the desired power output with the PC Volume control panel settings, you may have to resort to adjusting the levels with the rig microphone gain control. Ideally, you leave the microphone gain control at the normal voice position and do all the adjustments with the PC volume control and the interface knob.

You are now ready to install the Audio Transducer on the interface.

Note: Once the microphone gain and PC audio level settings are set up, write them down so you can set them there again if they get moved. All Transmit Drive setting done in normal operation is done with the knob on the interface. You will find that the output power at a particular knob setting will vary from band to band, and sometimes within the frequency range of the audio waterfall. That is the beauty of having the knob control on the interface - you will not have to change the microphone gain or the PC Wave level very often, if at all.

7.4.2.8 Install the Audio Transducer and Set the Audio Monitor Level

Install the Audio Transducer on the interface board. Adjust the height of the transducer such that the top of the transducer is no more than 0.45 inches above the top of the board. See Figure 5.1

Reinstall all cables, and put the switch in the OFF position. Now click on the **Digipan T/R** button to enter TX mode. Normally you would be transmitting now, but we left the PTT control in the OFF position so everything is being performed except actually keying the rig. This lets you set up your monitor level without actually transmitting. You should hear a tone coming out of the audio transducer speaker.

Note: When the transducer is first used, you may notice a few seconds delay before the sound comes out. There is a slow acting ALC built into the transducer that controls the output level. Subsequent uses of the monitor will be much faster.

If the output is too loud, bring up the PC volume control panel again using the **Digipan Configure/Transmitter Drive**. At the top of the Wave panel, there is a Balance slider that goes left/right. Slide the pointer to the left. This is an “attenuator” control for the stereo output. Sliding it to the left attenuates the left channel, while leaving the right channel at full output. As you move the balance in the left direction, you should hear the level on the audio monitor decrease. Select a comfortable listening level. You can “mute” the monitor by moving the slider all the way to the left.

If nothing happens to the monitor level when you move the slider to the left, try moving it to the right instead. Perversely, some sound cards or PC's have opposite definitions of what “left” and “right” is.

If the sound coming from the audio transducer is too low, increase the level on the sliders for WAVE until the sound is at a satisfactory level. You will have to readjust the Transmit Drive potentiometer after this is done to get the correct output when the PTT is applied.

Turn off the sound output by pressing the **Digipan T/R** button. It should return to RX mode, and the LED on the interface should go off. Put the PTT switch in the **AUTO** position. You are now ready for your first QSO.

7.4.3 Your First QSO - When the settings are finalized, you are ready to try your first QSO. You will use observations by other hams to determine the quality of your signal, and to help in any fine tuning of levels. This section will help you understand what they are reporting and what you can do if they see a problem.

7.4.3.1 Tune up away from other stations - Tune up the transmitter to your antenna at a frequency on the waterfall that is not near an occupied spot (more than 100 Hz away)

7.4.3.2 Look for a CQ - You will find that hams operating PSK31 and other sound card modes are very willing to welcome and help newcomers to the mode. You will be doing the same yourself, very soon! Look for a signal that is reasonably strong calling CQ. Double click on the CALLSIGN in the receive window. It will be copied to the “Call” field at the top left of the Digipan screen. When you click on the “Call” Macro button to call back, it will use the value in the “Call” field in the macro, along with your own callsign that you entered in the general setup at the beginning.

This is what should happen. When you click on the macro, it will turn on your rig, send the CQer's call sign, put in your call sign, and then turn your transmitter off. If the macro does not turn off the transmitter after everything is set, click on the **Digipan T/R** button to revert to RX mode. Some macros have not been set up to return to RX mode at the end. You should fix those macros by adding <RXANDCLEAR> at the end of the macro.

7.4.3.3 Getting an IMD report - If you are lucky, the called party will come back to you and you are on your way. After your normal greetings, ask "what does my signal look like" and ask for an IMD report.

7.4.4 The IMD Report - IMD (InterModulation Distortion) measurement is a standard way of representing the quality of a PSK31 signal. It is part of most of the software packages, including Digipan, MixW and others. It is measured when your system is IDLING (no typing, buffer empty). Idle generates a two tone signal 31 Hz wide centered on your audio "carrier". The receiving station software then looks at the harmonic at 62 Hz and measures the signal level there. The drop in signal between the fundamental and the harmonic is the IMD measurement, represented as a negative dB number. A good signal will have the harmonic 24 dB down (-24 dB on the display) or more. Acceptable signals can run down to -18 or -20 but you should strive for -24 or better. Really clean stations run at -30dB or better. A bad signal will be around -10 to -12 dB. You will learn to recognize them because you will see "sidebars" on the waterfall or spectrum display.

If the report is "clean", say around -24dB, you are done with your set up. If your report is poor, you might try reducing power a bit, say from half power to quarter power and see if the IMD goes up.

If you do get a low IMD number, but the report is that you "look pretty good", it may be that there is a problem in the IMD measuring system. Low level signals operating near the noise level will have poor IMD measurements. So will signals that are very strong (S9 or more) if the receiving party has not reduced their RF gain to inhibit their local AGC action. Get reports from several hams until you are satisfied that you have a clean station.

Other problems that can be reported are: spurs of your signal a few hundred Hz above or below your main signal; signals about 120 hz apart (hum) on your signal; broadband noise in the band when you are transmitting. These problems and their cures are covered in section 7.5.

If you have a good ground, are using shielded cable, have low levels of RF in your shack, are using an isolating interface, and have followed the setup procedure above, you should be getting good reports. Enjoy these modes and good DX!

7.5 Common Problems and Their Cures

In spite of your best efforts, sometimes there may be quality problems with your signal. This section describes common problems and offers some cures for them.

7.5.1 Spurs on Your Signal - this is characterized by a signal appearing several hundred Hz above or below your signal when you transmit. It may have data on it and oddly, it is the same data that you are transmitting! This is a spur or harmonic of your modulated audio carrier appearing in the output audio passband of your transceiver. It may be caused by:

- Your compression being ON - turn it off.
- Your Tx audio signal level being too high - reduce the drive level.
- Your transmitter RF output being set below the level you would normally transmit at if the RF gain had not been reduced. Turn it up higher and control your level with the Interface Tx Level control instead.
- Non-linearity in the audio path of your transceiver. Try changing the mic gain setting to see if there is a level which works better.
- The reporting station has an improperly set up receiver. If the signal is strong, and the receiving station is using a tight filter, spurs can be generated in his receiving equipment. The receiving station should reduce the receive RF gain and go to a broader receive filter to check this.
- You are operating outside of the audio passband of your transceiver. See section 7.4.2.3.

7.5.2 Hum on Your Signal - characterized by signal appearing 60Hz or 120Hz apart as viewed on the observing parties waterfall whenever you transmit. It may be caused by:

- Poor shielding on your audio cables - are they really shielded?
- Poor grounding of system components. Check system grounding.
- RF Feedback getting into your Sound Card - modify your audio cables as described in 7.6 below.

7.5.3 Wideband Noise on Your Signal - as seen on the observers waterfall. Appears when you transmit. Your IMD and actual signal may be fine, but there is all this NOISE being generated too! It may go away when you reduce your drive level.

- RF feedback getting into your system. Use an isolated interface like the one described in this document.
- RF feedback getting into the sound card Line In (or other slot) and being amplified. Filter your cable as described in section 7.6 below.
- RF feedback getting into the sound card through other inputs - deselect all sources for the Rx level control on the PC as described in 7.3.1 above and mute all sources for output as described in section 7.4.1 above.
- Reduce RF levels in the shack by using coax from the tuner to the antenna.

7.5.4 Other Strange Audio Being Produced by Your Signal - these sounds may be recognizable, like music or voices from the shack, or strange audio tones moving up and down the band, or PC sounds like Windows alerts.

- Voices, music or other sounds from the shack is getting into the mic of the transceiver. Some rigs have their microphone active when using the ACC port. Disconnect the microphone.
- Another microphone is on your PC, sometimes mounted in the monitor. Mute the sources as described in section 7.3.1 and 7.4.1 above.
- Weird tones moving around like a slow sawtooth oscillator are caused by RF getting into unused inputs on the Sound Card. Section 7.3.1 and 7.4.1 again.

7.5.5 Break Up of Your Audio When Transmitting - gaps in your transmitted signal when sending data. You may also notice that the PTT light goes on and off while transmitting.

- Other programs on your PC are stealing too much time from the sound card program. De-activate the other programs, or get a faster PC
- Bad connections in the interface, check soldering on all joints on the circuit board.
- Bad connections in the audio cables or in the rig control cable
- Transceiver problems

7.6 Filtering the Audio Cables - most problems which are RF related are cured by using the isolating interface described in this design document, using shielded cables and grounding the system properly. But there are some tough environments that still manage to get RF into the sound card system through the "Line In" cable.

Some success in curing this has been found using ferrite beads on the audio cable just before it plugs into the sound card "Line In", Same idea works on the audio line going into the rig too. Two sources for ferrite beads are Amidon and Palomar-Engineers.

Amidon	www.amidoncorp.com
Palomar-Engineers	www.palomar-engineers.com